

# ESCORTS



## HYDRA 15

3P



Capacity  
**15 T**



Boom Height  
**42 Feet**



Service Interval (Engine)  
**500 hrs.**



Straight Axle  
**Heavy Duty**



Structure  
**Robust**

## SPECIFICATIONS



### RATED CAPACITY

15 Tonne at	1.6 m radius
2.0 Tonne at	9.9 m radius



### ENGINE

Make & Model	Escorts AE 4.312C-3A four cylinder, water cooled diesel engine, developing 49.5 HP @ 2200 RPM or equivalent
--------------	---

\*500 hrs service interval available in escorts engine.



### TRANSMISSION

Drive Type	2 Wheel drive Heavy duty transmission developed especially for crane application. Constant mesh gearbox coupled with straight drive axle. Eight forward and two reverse speeds with high/low selector lever
Creep Speed	1.9 km/hr, ideal for crane operation
Max. Speed	29 km/hr. (unladen)
Clutch	Heavy duty clutch, wire woven, asbestos free



### STEERING

Type	Articulated power steering, hydraulically controlled through 2 double acting jacks
Articulation	Up to 56°
Turning Radius	6.75 m



### BRAKES

Front Wheel	Pneumatic assisted hydraulic brakes
Rear Wheel	Disc brakes actuated through a slave cylinder
Parking	Hand control valve operated, Air assisted Hydraulic parking brakes at all wheels (Standard models) Hand control valve operated, Air assisted Parking brakes at Front wheels (with front Air brake models)



### TYRES

Front	11.00 X 20 -16 PR (4 nos.), inflation pressure 110 – 115 PSI
Rear	13.00 X 24 -12 PR (2 nos.), inflation pressure 35 PSI. Water ballasted



### TRACK

Front	1980 mm
Rear	1680 mm



### BOOM

Telescoping	3 parts hydraulically powered & fully synchronized
Type	Slotted boom with rope compensation
Derricking	Through double acting jacks



### HOIST MECHANISM

Hoist	Hydraulic winch. Six falls (Winch capacity 12 T). Rope dia 13 mm
-------	--



### HYDRAULIC SYSTEM

Pump	Vane type hydraulic pump
Control Valve	4 spool control valve with built in pressure relief valve and precision control
Hydraulic Filter	Suction line has a 100 mesh in-line strainer while return line has 25 microns full flow filter



### ELECTRICAL SYSTEM

Type	12V Single battery, Negative earth
------	------------------------------------



### CAPACITIES

Fuel Tank	38 ltrs.
Hydraulic Tank	65 ltrs.



### OVERALL DIMENSIONS

Length	11900 mm
Width	2550 mm
Height	3100 mm



### OPERATING WEIGHT (KG)

Gross Vehicle Weight	11700 kg
----------------------	----------



### SAFETY SYSTEM

- Rope compensation for auto leveling
- Overload audio warning system
- Hose protection failure device
- Safety brakes on hoist
- Cylinder guard for protection
- System Low air pressure warning buzzer



### STANDARD ACCESSORIES

- All Weather Cabin
- Lift Cylinder Guard
- Turn & Reverse Lamp
- Front Bumper
- Rear View Mirror
- Reflectors



### OPTIONAL ACCESSORIES

- Fly Jib
- Spark Arrestor
- Steering Wheel
- Safe Load Indicator
- 14 x 24 Heavy Duty Tyres
- Air Brakes on Front Wheel
- Over Hoist & Hydraulic Cutoff Kit
- Tool Box
- Fire Extinguisher
- Heavy Duty Bumper

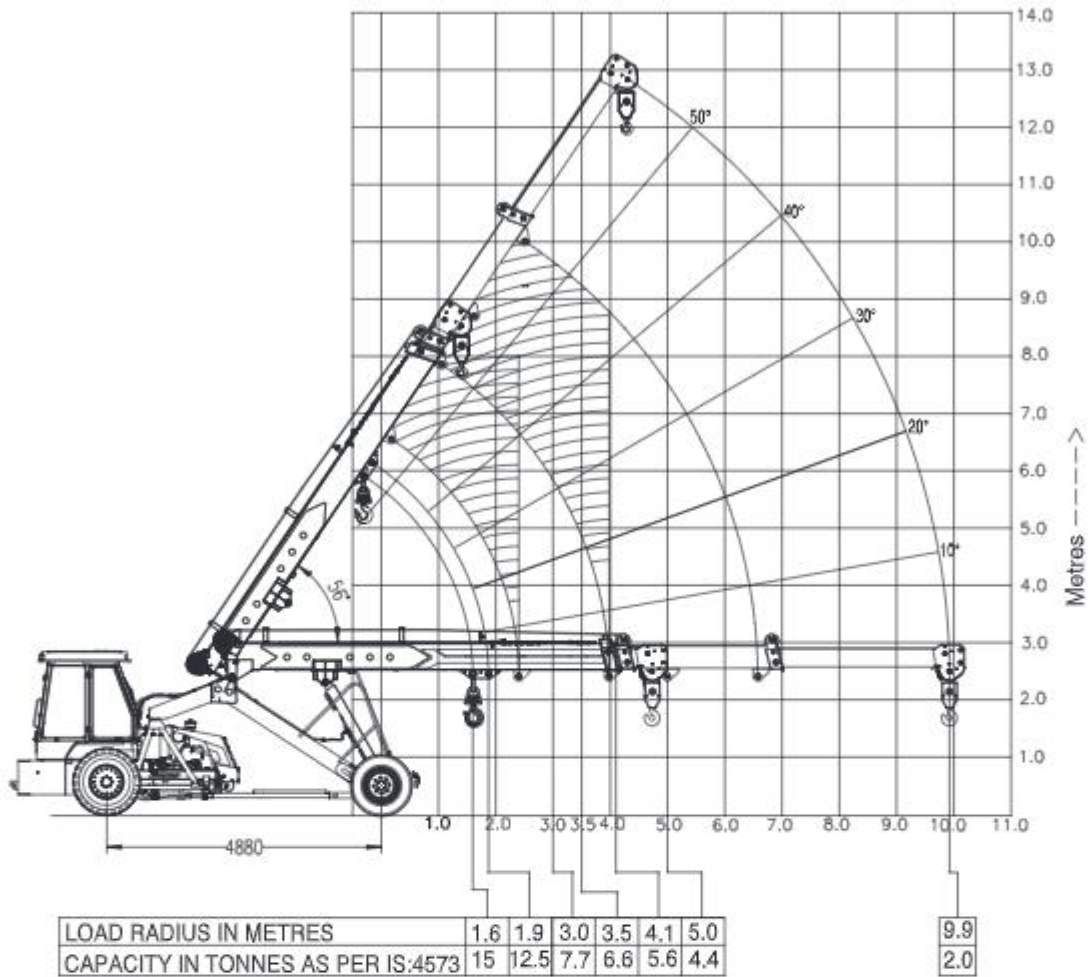

Rated loads are calculated for operation on leveled surface.

## FEATURES



### BOOM

Slotted Boom & Rope Compensation for precision handling & auto leveling of loads.



### TRANSMISSION

Heavy duty straight axle with constant mesh transmission.



### CABIN

Ergonomically designed spacious cabin with modern dashboard for utmost operator comfort and operation.



### REAR BRAKES

Disc brakes at the rear for effective braking



### HYDRAULIC WINCH OF 12T

Capacity with 6 falls snatch block for precision handling & low maintenance.



### ENGINE

Escorts engine BS-III (CEV compliant) high on power/ torque & low on fuel consumption & maintenance.





## OUR REACH

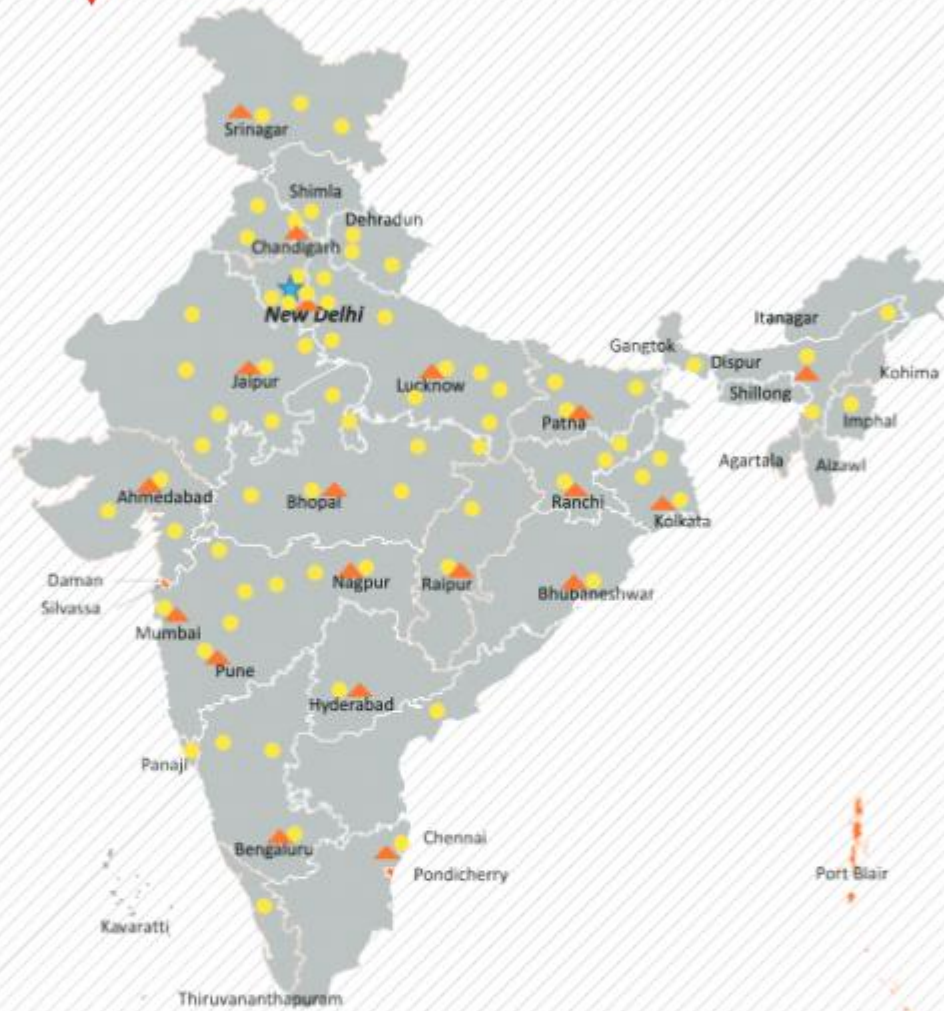

★ Head Office | ▲ 17 Business Center | ● 73 Dealers | ■ 825+ Customer Touch points (CTP)



**Toll Free No.:**  
**1800-180-4488**  
(Timings: 9:30 am - 6:00 pm, Monday to Friday)

e-mail: [eco.help@escorts.co.in](mailto:eco.help@escorts.co.in)

Escorts Kubota Limited (Formerly Escorts Limited) Construction Equipment  
Plot No. 219, Sector- 58, Ballabhgarh- 121 004, Faridabad, Haryana (INDIA)  
Tel.: 0129-2306574/2306598/2306571  
Fax: 0129-2306572 Website: [www.escortsgroup.com](http://www.escortsgroup.com)



GET IT ON  
**Google Play**  
Download Customer App  
for more details

Authorised Dealer

(Accessories as shown in the picture may not be the part of standard firm and are subject to change without prior notice.)

MKT/22/Hydra 15 3P