

ESCORTS



HYDRA 14

3P

ESCORTS HYDRA 14
14 T 10 T



Capacity
14 T



Boom Height
42 Feet



Service Interval (Engine)
500 hrs.



Straight Axle
Heavy Duty



Structure
Robust

SPECIFICATIONS



RATED CAPACITY

14 Tonne at	1.6 m radius
1.9 Tonne at	10.07 m radius



ENGINE

Make & Model	Escorts AE 4.312C-3A four cylinder, water cooled diesel engine developing 49.5 HP @ 2200 RPM or equivalent.
--------------	---

*500 hrs service interval available in escorts engine.



TRANSMISSION

Drive	2 Wheel drive
Type	Heavy duty transmission developed especially for crane application. Constant mesh gearbox coupled with straight drive axle. Eight forward and two reverse speeds with high/low selector lever.
Creep Speed	1.9 km/hr. ideal for crane operation (laden)
Max. Speed	29 km/hr. (unladen)
Clutch	Heavy duty clutch, wire woven, asbestos free.



STEERING

Type	Articulated power steering, hydraulically controlled through 2 double acting jacks.
Articulation	Up to 56°
Turning Radius	6.5 m



HOIST MECHANISM

Hoist	Hydraulic winch. Six falls (Winch capacity 12 T). Rope dia 13 mm
-------	--



BRAKES

Front Wheel	Pneumatic assisted hydraulic brakes
Rear Wheel	Disc brakes actuated through a slave cylinder
Parking	Hand control valve operated, Air assisted Hydraulic parking brakes at rear wheels (Standard models) Hand control valve operated, Air assisted Parking brakes at Front wheels (with Air brake models)



HYDRAULIC SYSTEM

Pump	Vane type hydraulic pump
Control Valve	4 spool control valve with built in pressure relief valve and precision control
Hydraulic Filter	Suction line has a 100 mesh in-line strainer while return line has 25 microns full flow filter



ELECTRICAL SYSTEM

Type	12V Single battery, Negative earth
------	------------------------------------



CAPACITIES

Fuel Tank	38 ltrs.
Hydraulic Tank	65 ltrs.



TRACK

Front	1980 mm (center of twin wheels)
Rear	1680 mm (center of wheels)



OVERALL DIMENSIONS

Length	11900 mm
Width	2550 mm
Height	3100 mm



OPERATING WEIGHT (KG)

Gross Vehicle Weight	11000 kg
----------------------	----------



BOOM

Telescoping	3 parts hydraulically powered & fully synchronized
Type	Slotted boom with rope compensation
Derricking	Through double acting jacks



TYRES

Front	11.00 X 20 - 16 PR (4 nos.), inflation pressure 110 — 115 PSI
Rear	13.00 X 24 - 12 PR (2 nos.), inflation pressure 35 PSI. Water ballasted



SAFETY SYSTEM

- Overload audio warning system
- Safety brakes on hoist
- Cylinder guard for protection
- Hose protection failure device
- Rope compensation for auto leveling
- System Low air pressure warning buzzer



STANDARD ACCESSORIES

- All Weather Cabin
- Lift Cylinder Guard
- Turn & Reverse Lamp
- Front Bumper
- Rear View Mirror
- Reflectors



OPTIONAL ACCESSORIES

- Fly Jib
- Tool Box
- Spark Arrestor
- Tyre Guard
- Steering Wheel
- Fire Extinguisher
- Safe Load Indicator
- Heavy Duty Bumper
- 14 x 24 Heavy Duty Tyres
- Air Brakes on Front Wheel
- Over Hoist & Hydraulic Cutoff Kit

**LOAD CHART
HYDRA 14 3P**

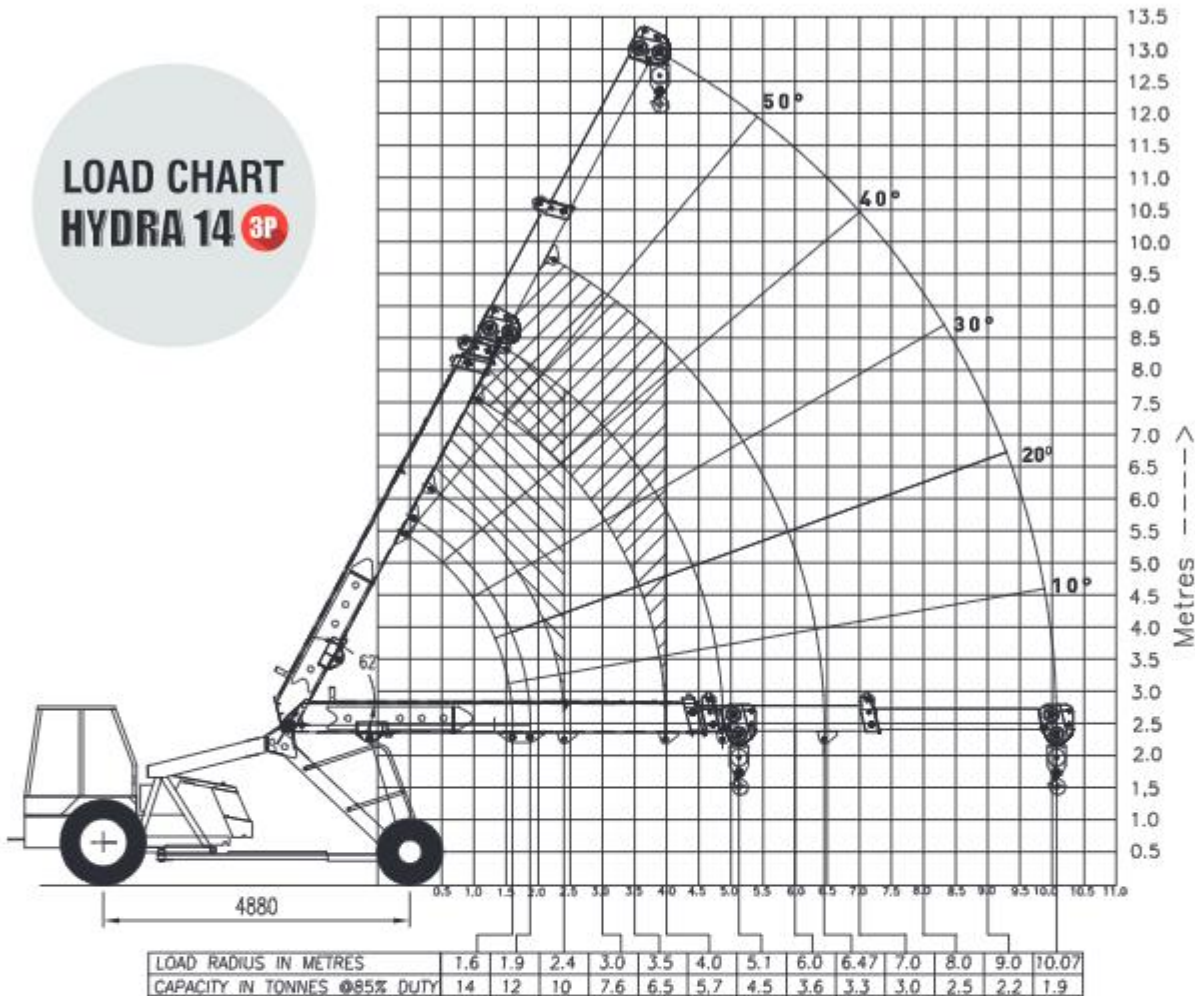

Rated loads are calculated for operation on leveled surface.

FEATURES



SLOTTED BOOM AND ROPE

Compensation for precision handling & auto levelling of loads.



TRANSMISSION

Heavy duty straight axle with constant mesh transmission.



CABIN

Ergonomically designed spacious cabin with modern dashboard for utmost operator comfort and operation.



REAR BRAKES

Disc brakes at the rear for effective braking



LIFT CYLINDER MOUNTING

Lift cylinders are mounted with adequate gap for better strength, stability & precision handling of loads.



ENGINE

Escorts engine BS-III (CEV compliant) high on power/torque & low on fuel consumption & maintenance.



OUR REACH

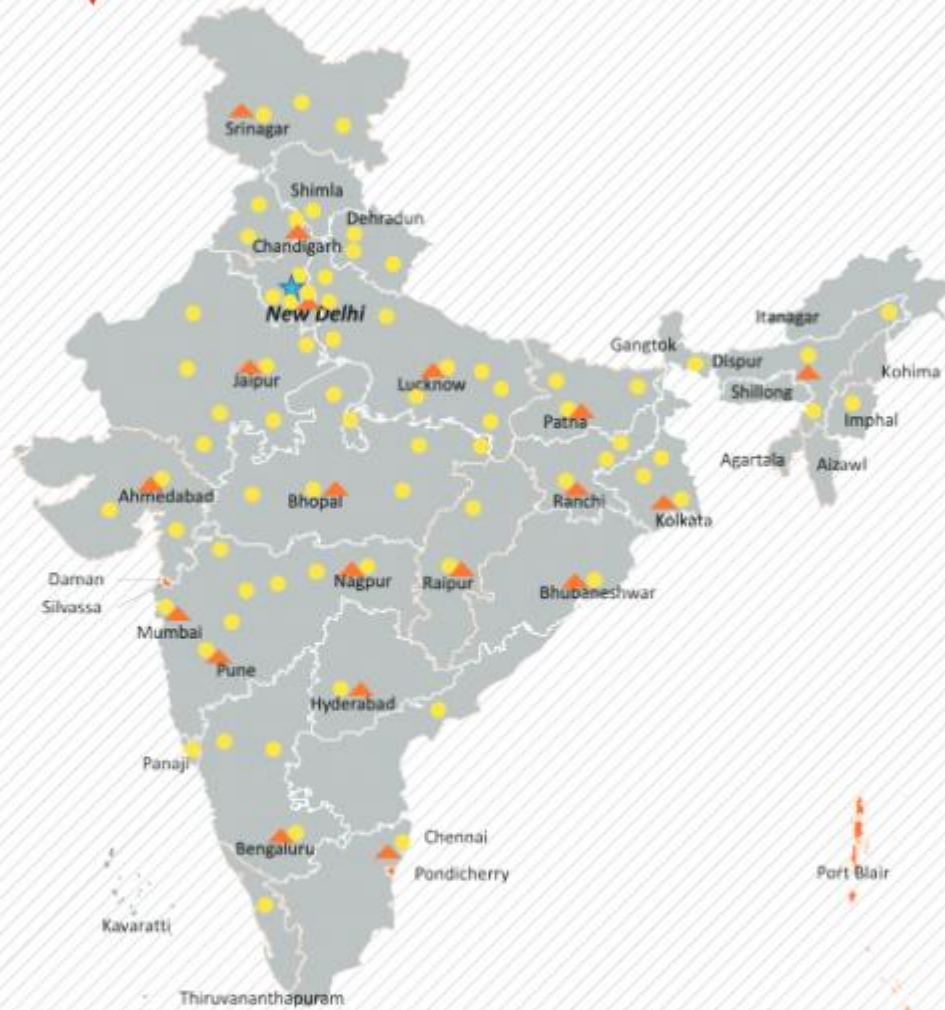

★ Head Office | ▲ 17 Business Center | ● 73 Dealers | ■ 825+ Customer Touch points (CTP)



Toll Free No.:
1800-180-4488

(Timings: 9.30 am - 6.00 pm, Monday to Friday)

e-mail: ece.help@escorts.co.in

Escorts Kubota Limited (Formerly Escorts Limited) Construction Equipment
Plot No. 219, Sector- 58, Ballabhgarh- 121 004, Faridabad, Haryana (INDIA)
Tel.: 0129-2306574/2306598/2306571
Fax: 0129-2306572 Website: www.escortsgroup.com



GET IT ON
Google Play

Download Customer App
for more details

Authorized Dealer