

EC 5250

**MORE POWER
ON THE GROUND**



Fuel
Efficient



Compaction Force
High



Gradeability
High



Travel Speed
Highest



Maintenance Cost
Low

SPECIFICATIONS



ENGINE

Make	KOEL
Model	4R1190TA1
Type	4 Cylinder, Water Cooled, CEV STAGE-IV Emission Norms
Combustion System	Difect Injection
Aspiration	Turbocharged after cooled
Rated Power (Gross)	110 HP @ 2200 RPM
Fuel Injection Pump	Common Rail System



STEERING

Steering Angle	Deg	+/- 36
Oscillation Angle	Deg	+/- 10
Turning Radius Outer/Inner	mm	5500/3370



DRIVE

Hydrostatic Drive	Rear	All	All
Infinitely Variable	Wheel	Wheel	Wheel



WEIGHT

	Unit	STD	DD	PD
Max Operating Weight	kg	10350	10550	11950
Operating Weight	kg	9350	9550	10950
Axle Load - Front	kg	5050	5250	6650
Axle Load - Rear	kg	4300	4300	4300
Static Liner Load	kg/cm	23.7	24.6	-
Centrifugal Force - Low	kg	9046	9046	9046
Centrifugal Force - High	kg	21492	21492	21492
Total Applied Force - Low	kg	14096	14296	15696
Total Applied Force - High	kg	26542	26742	28142
Pad Foot	Nos.	-	-	120



SPEED

Working Speed	km/hr	0-9	0-6	0-6
Traveling Speed	km/hr	0-23	0-10	0-10



GRADEABILITY

Make Gradeability	%	40	55	55
-------------------	---	----	----	----



VIBRATION SYSTEM

Frequency	Hz	30	30	30
High Amplitude	mm	1.72	1.72	1.3
Low Amplitude	mm	0.8	0.8	0.5



CAPACITY

Fuel Tank	Ltr	265
Hydraulic Oil Tank	Ltr	80
Drum Oil	Ltr	5



BRAKES

Service Brakes	Hydrostatic
Parking Brakes, Emergency Brakes	Spring applied, hydraulically released



TYRES

2 nos., All Weather Pattern 23.1 / 26-8 PR



DIMENSIONS

	Unit	STD	DD	PD
Overall Width	mm	2275	2275	2275
Overall Length	mm	5460	5460	5460
Overall Height	mm	3045	3045	3095
Drum Diameter	mm	1523	1523	1739
Drum Width	mm	2130	2130	2130
Ground Clearance	mm	435	435	485
Wheel Base	mm	2880	2880	2880
Drum Shell Thickness	mm	25	25	25



SALIENT FEATURES

- Canopy with Sun Top
- RPM Gauge,
- Fuel Level Gauge
- Joystick
- Mobile Charger
- Vandal Cover
- Dust Guard
- Bottle Hanger
- Rear View Mirrors 2 nos.
- LED Work Lights 3 nos.
- Anti Slip Pad on Platform
- Tail Lamp 4 Chamber



SAFETY FEATURES

- Neutral Start Safety
- Emergency Brake Switch
- Air Filter Clog Indicator
- Hydraulic Filter Clog Indicator
- Low Engine Oil Pressure Indicator & Alarm
- Hydraulic Oil Temperature Gauge
- Battery Charging Indicator
- Starter Safety Relay
- Coolant Temperature Gauge & Indicator
- Vibration Cutoff at Neutral & Parking Brake
- Engine Shutoff at High Coolant Temperature
- Over Cranking Protection
- Battery cut off switch



OPTIONAL EQUIPMENT

- Cold Starring Kit
- Engine Cut Stop at Low Pressure
- Compactobar with Frequency Meter
- Intelligent Compaction System (ICS)
- Delay Start with Warning Alarm

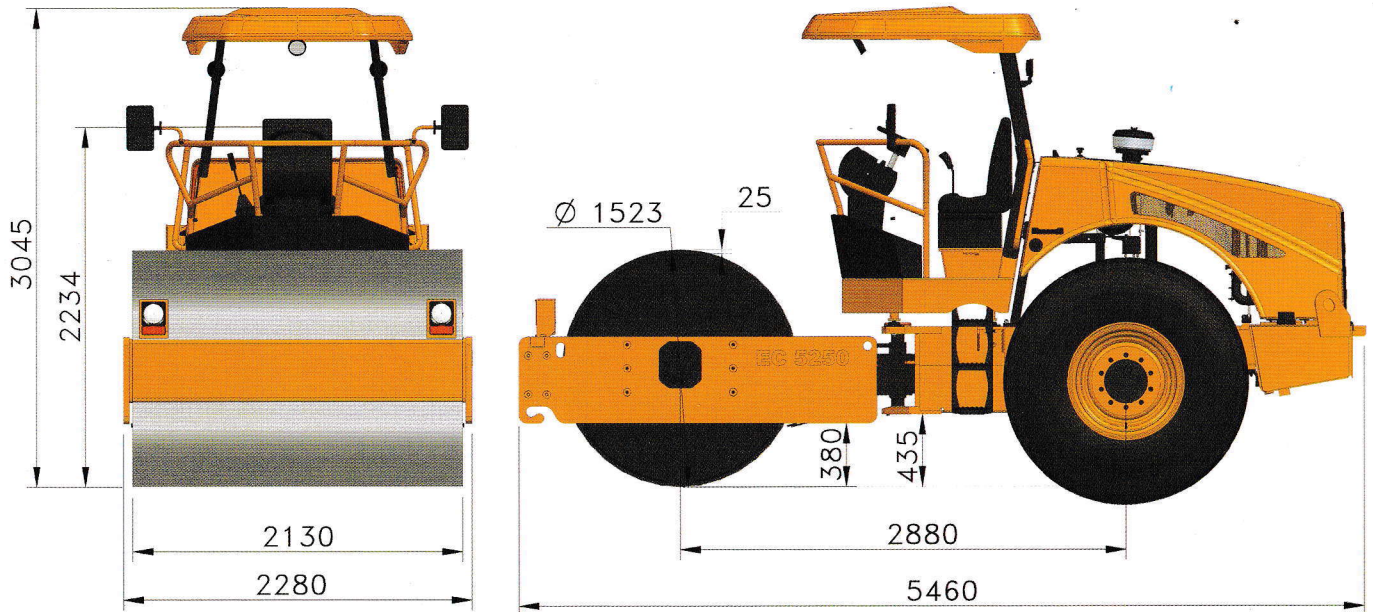

FEATURES

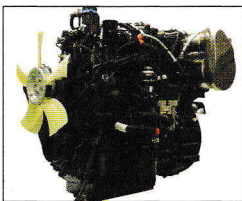

ENGINE
 KOEL 4R1190TA1 CEV STAGE-IV
 Emission Norms engine is
 high on power and traction.
 Low on fuel consumption
 and maintenance.



GRADEABILITY
 High gradeability
 makes it versatile
 for all applications.

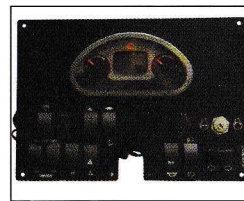

INSTRUMENT PANEL
 Instrument Panel with
 conveniently placed switch for
 ease of operation, mobile charge
 & IP 67 compliant electrical
 connectors for high reliability.



OPERATOR PLATFORM
 Comfortable operator platform
 with ergonomically located
 joystick, controls, adjustable
 seat & excellent all around
 visibility.



STEERING ANGLE
 Articulation Steering Angle is
 high for low turning radius.



TRAVEL SPEED
 Highest travelling speed in
 the industry which increases
 productivity by reducing idle
 time, during travel from one
 site to another.



LED WORK LIGHTS
 1 front & 2 rear LED
 work lights for smooth
 operation at night.

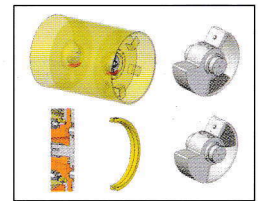

RUGGED DRUM ASSEMBLY
 Cartridge type Eccentric weight.
 Separate case housing for oil.
 Heavy Duty DUCONE metal seal.

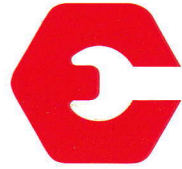

OUR REACH

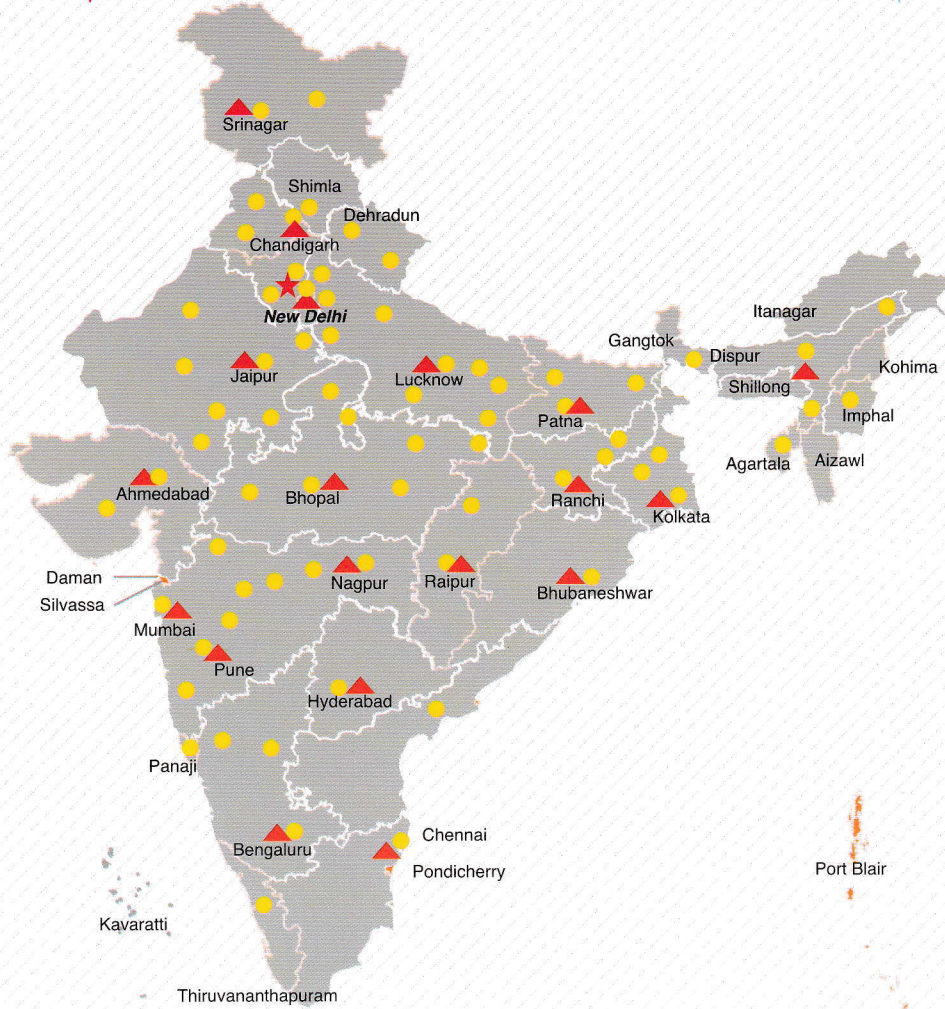

★ Head Office ▲ 17 Business Center ● 73 Dealers & 250+ branches ■ PAN INDIA - 825+ Network to support as Service and Spares



Toll Free No.:
1800-180-4488

(Timings: 9.30 am - 6.00 pm, Monday to Friday)

e-mail: ece.helpline@escorts.co.in

Escorts Construction Equipment: Plot No. 219, Sector- 58, Ballabgarh- 121 004, Faridabad, Haryana (INDIA) Tel.: 0129-2306574/2306598/2306571 Fax: 0129-2306572 Website: www.escortsgroup.com

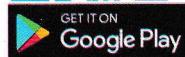

Download Customer App for more details

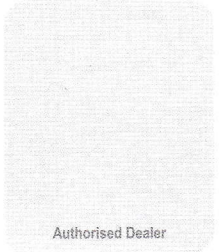

Authorised Dealer